

Name \_\_\_\_\_

Give the ordered pairs that correspond to the points labeled in the figure.

1)

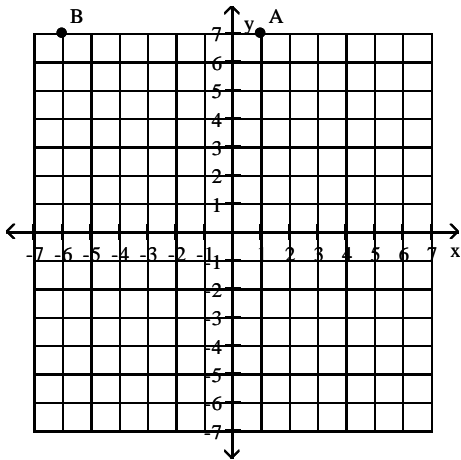

2)

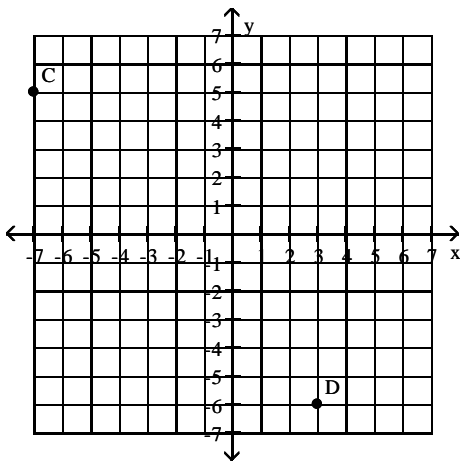

3)

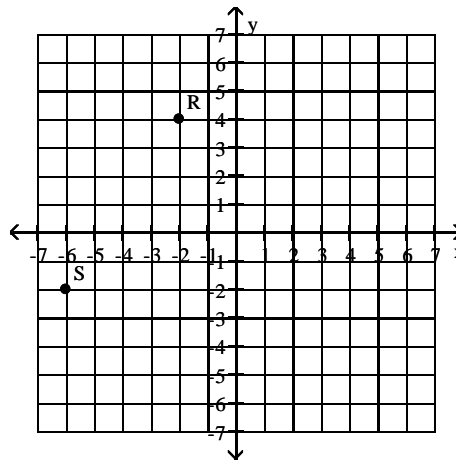

4)

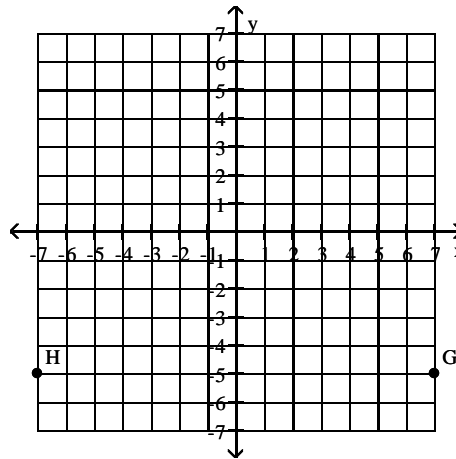

Determine whether the ordered pair is a solution of the given equation.

5) (4, 1)  
 $y = x - 3$

6) (3, -3)  
 $y = x - 6$

7) (-3, 4)  
 $y = x - 1$

8) (2, 1)  
 $y = x - 3$

9) (3, -6)  
 $x - y = 9$

10) (2, -4)  
 $x - y = 6$

11) (-6, -2)  
 $x - y = 8$

12) (-2, 3)  
 $x - y = -1$

13) (1, 4)  
 $3x + 4y = 19$

14) (-2, 1)  
 $3x + 2y = -4$

15) (-4, -2)  
 $2x + 4y = 0$

Graph the linear equation in two variables.

16)  $y = 2x$

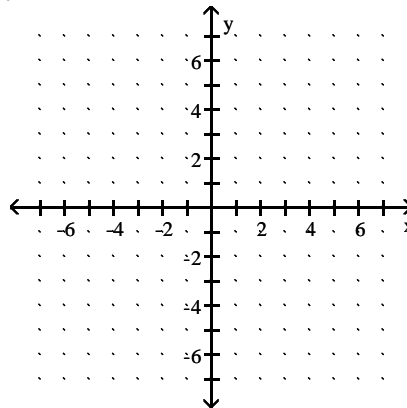

17)  $y = -6x$

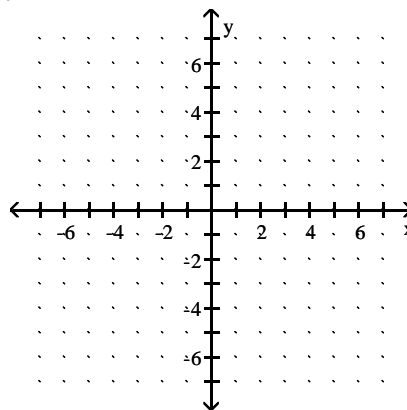

18)  $y = x + 3$

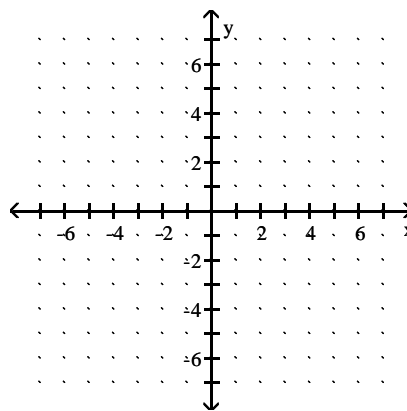

19)  $y = -x + 4$

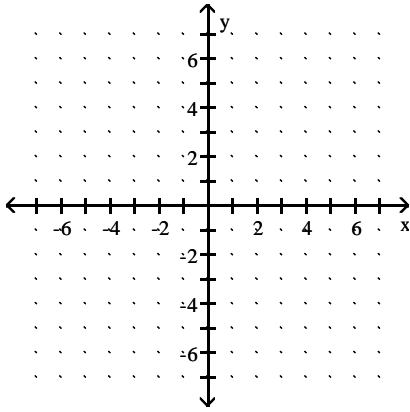

22)  $y = \frac{1}{3}x - 6$

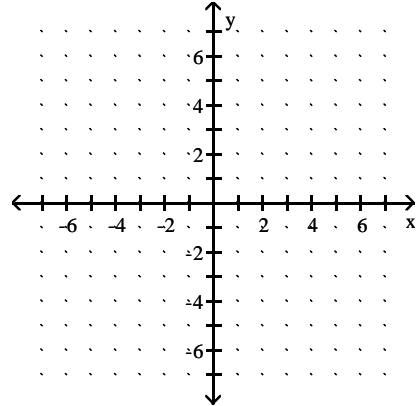

20)  $y = 5x - 2$

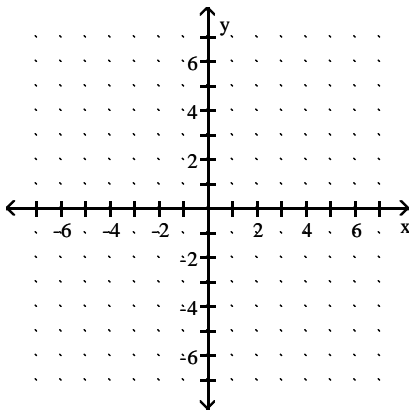

23)  $y = \frac{1}{4}x + 2$

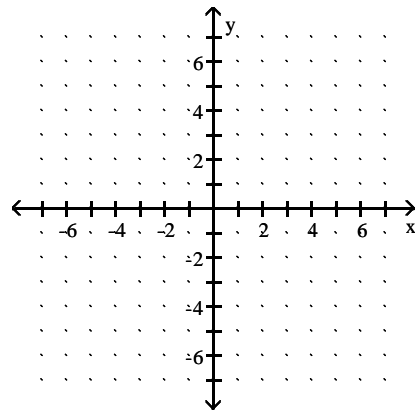

21)  $y = -3x + 3$

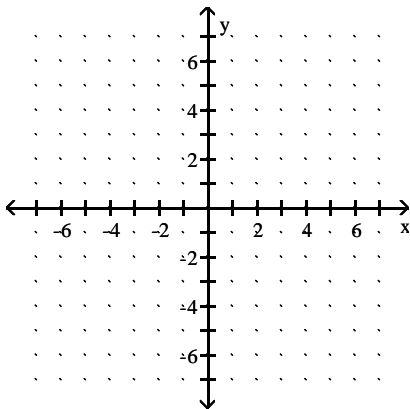

24)  $y = \frac{1}{3}x - 4$

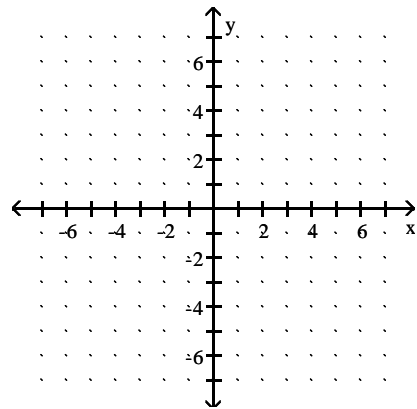

**Solve the problem.**

- 25) A customer at a store bought 5 bottles of juice and 8 fruit pies for a total cost of \$105.25. If  $x$  represents the cost of a bottle of juice and  $y$  represents the cost of one fruit pie, write an equation in two variables that reflects the given conditions.
- 26) A customer at a store bought 4 bottles of juice and 5 fruit pies for a total cost of \$66.00. If  $x$  represents the cost of a bottle of juice and  $y$  represents the cost of one fruit pie, write an equation in two variables that reflects the given conditions.
- 27) A customer at a store bought 4 bottles of juice and 8 fruit pies for a total cost of \$83.00. If a bottle of juice costs \$3.75, find the cost of a fruit pie.
- 28) A customer at a store bought 8 bottles of juice and 4 fruit pies for a total cost of \$72.00. If a bottle of juice costs \$4.25, find the cost of a fruit pie.
- 29) A customer at a store bought 3 bottles of juice and 6 fruit pies for a total cost of \$72.75. If a bottle of juice costs \$2.25, find the cost of a fruit pie.
- 30) The linear equation in two variables  $y = 0.25x + 200$  models the total weekly cost,  $y$ , in dollars, for renting a car and driving it  $x$  miles. The equation indicates that the rental company charges a fixed amount of \$200 for the week plus a cost of \$0.25 for each mile the car is driven. Find a solution of  $y = 0.25x + 200$  using 425 for  $x$ .
- 31) The linear equation in two variables  $y = 0.25x + 225$  models the total weekly cost,  $y$ , in dollars, for renting a car and driving it  $x$  miles. The equation indicates that the rental company charges a fixed amount of \$225 for the week plus a cost of \$0.25 for each mile the car is driven. Find a solution of  $y = 0.25x + 225$  using 350 for  $x$ .
- 32) The linear equation in two variables  $y = 3x + 40$  models the total cost,  $y$ , in dollars, for towing a car  $x$  miles. The equation indicates that the towing company charges a fixed amount of \$40 to send a truck to pick up the car plus a cost of \$3 for each mile the car is towed. Find a solution of  $y = 3x + 40$  using 14 for  $x$ .
- 33) The linear equation in two variables  $y = 3x + 70$  models the total cost,  $y$ , in dollars, for towing a car  $x$  miles. The equation indicates that the towing company charges a fixed amount of \$70 to send a truck to pick up the car plus a cost of \$3 for each mile the car is towed. Find a solution of  $y = 3x + 70$  using 4 for  $x$ .
- 34) The linear equation in two variables  $y = 2x + 75$  models the total cost,  $y$ , in dollars, for towing a car  $x$  miles. The equation indicates that the towing company charges a fixed amount of \$75 to send a truck to pick up the car plus a cost of \$2 for each mile the car is towed. Find a solution of  $y = 2x + 75$  using 3 for  $x$ .
- 35) A customer at a store bought 4 bottles of juice and 6 fruit pies for a total cost of \$73.00. If  $x$  represents the cost of a bottle of juice and  $y$  represents the cost of one fruit pie, write an equation in two variables that reflects the given conditions.

# Answer Key

Testname: Q05PREP\_3.1, &3.2V01

- 1)  $A = (1, 7), B = (-6, 7)$
- 2)  $C = (-7, 5), D = (3, -6)$
- 3)  $R = (-2, 4), S = (-6, -2)$
- 4)  $G = (7, -5), H = (-7, -5)$
- 5) Yes
- 6) Yes
- 7) No
- 8) No
- 9) Yes
- 10) Yes
- 11) No
- 12) No
- 13) Yes
- 14) Yes
- 15) No
- 16)

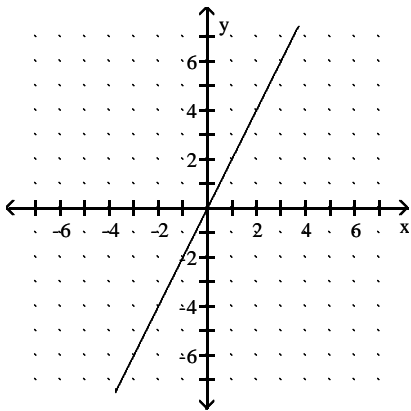

17)

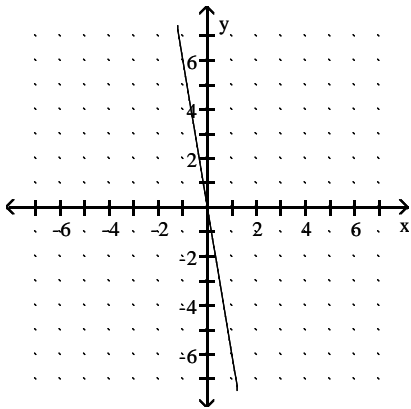

Answer Key

Testname: Q05PREP\_3.1, &3.2V01

18)

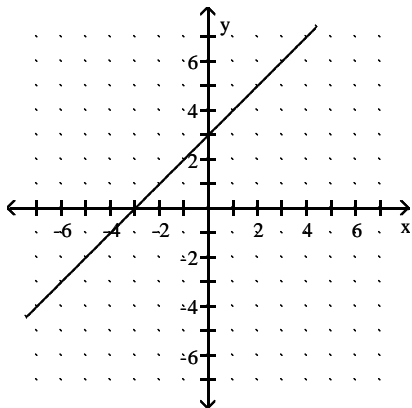

19)

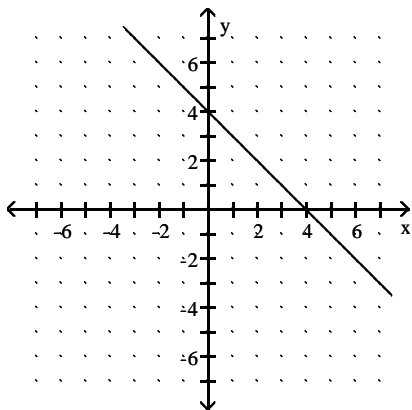

20)

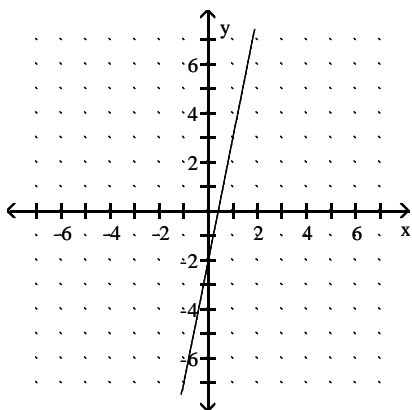

Answer Key

Testname: Q05PREP\_3.1, &3.2V01

21)

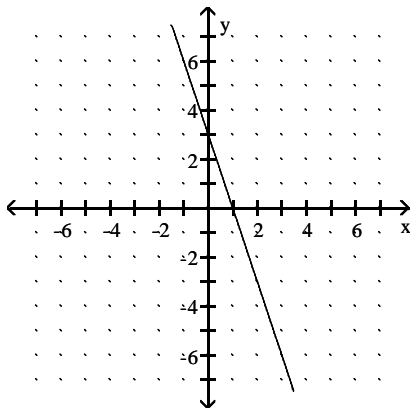

22)

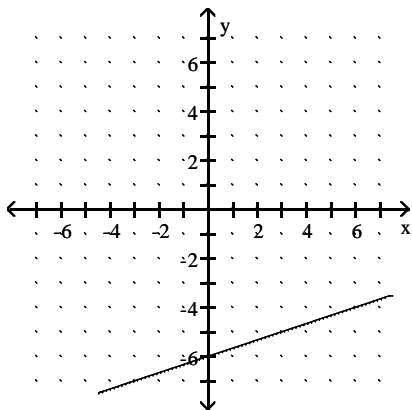

23)

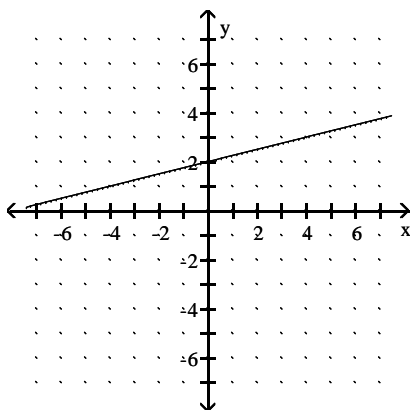

Answer Key

Testname: Q05PREP\_3.1, &3.2V01

24)

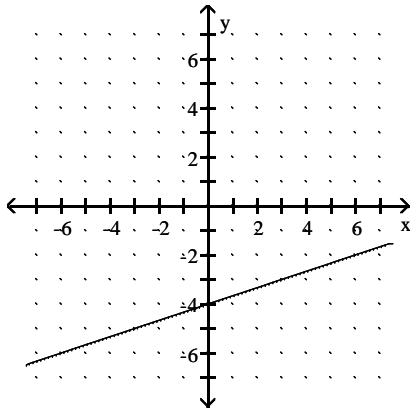

25)  $5x + 8y = 105.25$

26)  $4x + 5y = 66.00$

27) \$8.50

28) \$9.50

29) \$11.00

30) (425, 306.25)

31) (350, 312.5)

32) (14, 82)

33) (4, 82)

34) (3, 81)

35)  $4x + 6y = 73.00$